

**Step #1**

Position the cover (in closed position) on the spa making sure that all four corners are properly positioned and square on the spa.

**Step #2**

Attach the cover mounting bracket to the side of the cover, 12 inches from the back edge of the cover using the supplied 3M glue adhesive. *Note: When standing in front of the spa, the cover mounting bracket-left will be attached to the left side of the cover. When applying 3M adhesive, make sure to apply it to both the vertical and horizontal sides of the cover mounting bracket where they come in contact with the vinyl cover (see Fig. 1).*

**Step #3**

Attach the rubber bumper to the Vanish XL front pivot arms using the supplied #8 x 1-1/4" self-tapping screw (see Fig. 2).

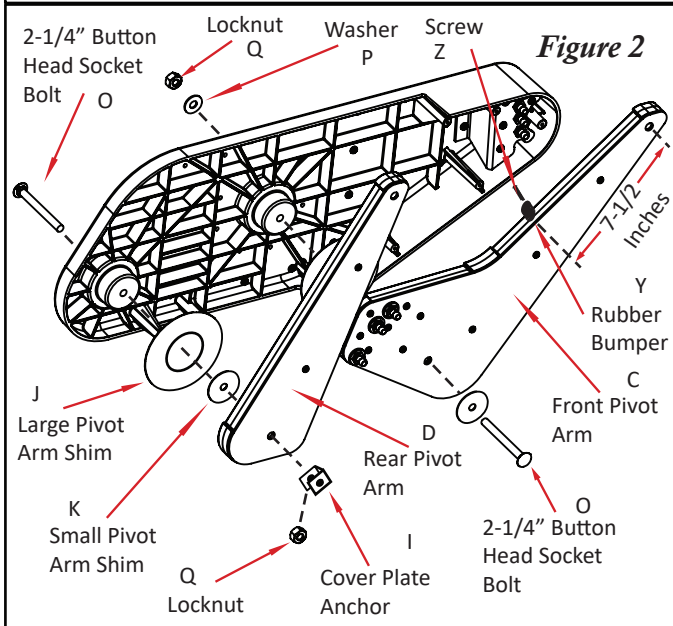

**Step #4**

Attach the Vanish XL pivot arms to the Vanish XL base mounting brackets (see Fig. 2). *Note: Make sure to install the large and small pivot arm shims as shown. Make sure the pivot arms rotate freely, do not overtighten bolts.*

**Step #5**

Attach the Vanish XL pivot arms to the cover mounting bracket attached to the cover using the supplied 2" button head socket bolts, washers, shims & locknuts and let the assembly hang freely (see Fig. 3). *Note: Make sure to run the bolts from the inside out. The locknuts need to be facing outwards. Also, make sure to use the supplied plastic washers as a spacer in between the metal plate on the pivot arms and the Vanish XL cover mounting bracket. Do not overtighten bolts, the pivot arms need to rotate freely.*

**Step #6**

Swing the Vanish XL bracket assembly up until the front and rear pivot arms make contact with each other (see Fig. 3). Attach the Vanish XL bracket assembly to the spa cabinet using the supplied #10 x 1-1/2" mounting screws.

**Step #7**

Repeat steps 2, 3, 4, 5 & 6 for the opposite side of the spa.

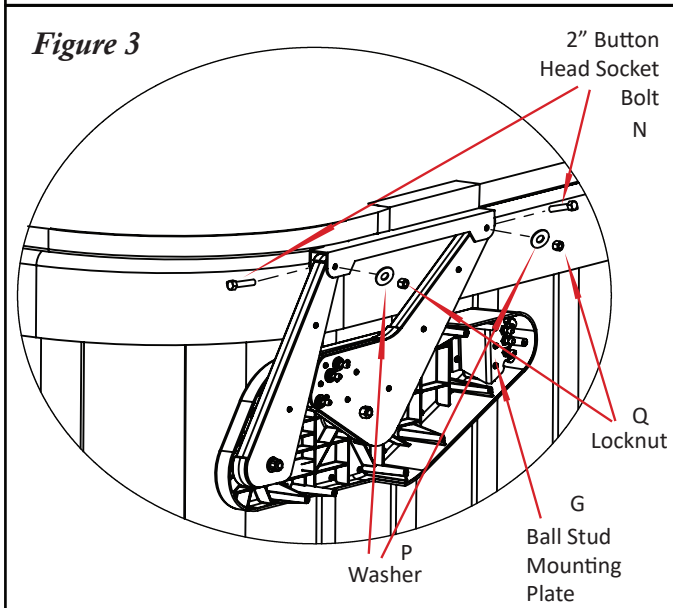

**Step #8**

To attach the shocks to the bracket assembly, partially open your vinyl cover and snap the shocks onto the appropriate ball studs (see Fig. 4). When attaching the shock to the front pivot arm, start with the top ball stud. Over time as your cover begins to get heavier, you may need to remove the shock and attach it to the bottom ball stud on the front pivot arm. *Note: Make sure the black body of the shock is pointing towards the middle of the spa.*

**Step #9**

Open the vinyl cover so it is in the fully open position. Using the supplied #10 x 1-1/2" mounting screws, finish attaching the Vanish XL bracket assembly to the spa.

**Step #10**

Attach the Vanish XL cover plate to the bracket assembly using the supplied pancake head self-tapping screws. Next, thread the 3/8 x 3/4" hex cap bolt through the hole in the cover plate that lines up with the rear pivot arm (see Fig. 5). *Note: Do not overtighten the hex cap bolt.*

## Operation of your Covermate Vanish XL

- 1) Fold the first half of the cover off the spa. Next, lift up and push the cover back behind the spa.

Figure 4

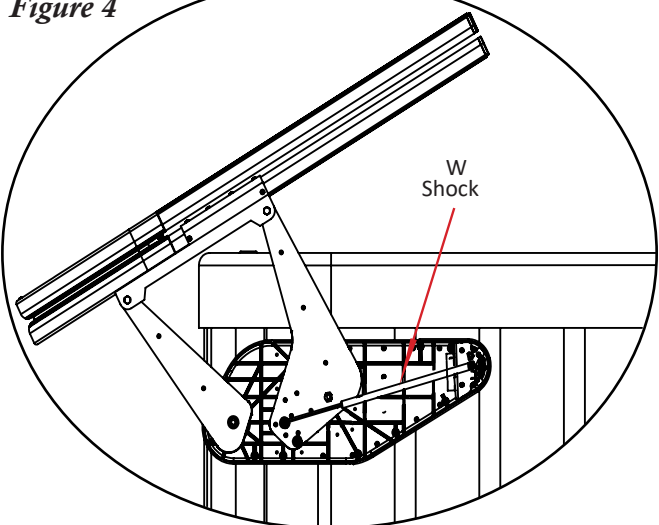
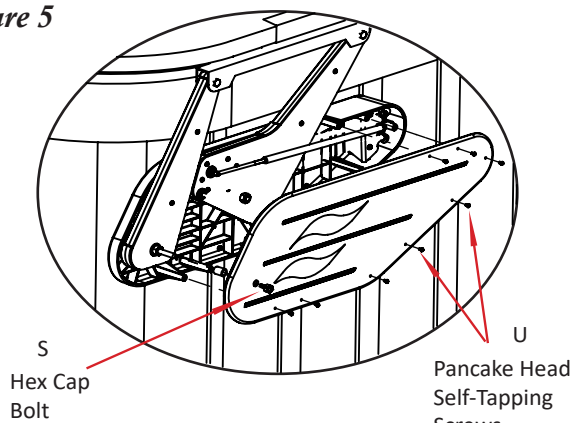

Figure 5



ITEM	PART#	DESCRIPTION	QTY
A(L)	101733	VANISH XL BASE BRACKET (L)	1
A(R)	101734	VANISH XL BASE BRACKET (R)	1
B(L)	101756	CM VANISH XL COVER MOUNTING BRACKET (L)	1
B(R)	101757	CM VANISH XL COVER MOUNTING BRACKET (R)	1
C	101737	VANISH XL PIVOT ARM - FRONT	1
D	101738	VANISH XL PIVOT ARM - REAR	1
E	101739	VANISH XL PIVOT ARM PLATE - FRONT	1
F	101740	VANISH XL PIVOT ARM PLATE - REAR	1
G(L)	101741	BALL STUD MOUNTING PLATE - LEFT	1
G(R)	101742	BALL STUD MOUNTING PLATE - RIGHT	1
H(L)	101743	VANISH XL COVER PLATE (L)	1
H(R)	101744	VANISH XL COVER PLATE (R)	1
I	101745	VANISH XL COVER PLATE ANCHOR	2
J	101746	LARGE PIVOT ARM SHIM	4
K	101747	SMALL PIVOT ARM SHIM	4
L	100244	5/16 BALL STUD	12
M	100032	5/16 NYLON LOCKNUT	12
N	101749	3/8 X 2" BUTTON HEAD SOCKET BOLT - BLACK ZINC	4
O	101758	3/8 X 2-1/4" BUTTON HEAD SOCKET BOLT - ZINC	4
P	100012	3/8 FLAT WASHER	6
Q	100011	3/8 NYLON LOCKNUT	4
R	101750	3/8 PLASTIC SHIM WASHER	4
S	101752	3/8 X 3/4" HEX CAP BOLT - BLACK ZINC	2
T	100909	#10 X 1-1/2" PHILIPS PAN HEAD MOUNTING SCREW	68
U	101748	#10 X 1" PHILIPS PANCAKE HEAD SCREW - BLACK ZINC	26
V	100015	LARGE BLACK DOME CAP	6
W	101510	SHOCK - 335N	2
X	101511	3M ADHESIVE	2
Y	101762	RUBBER BUMPER	2
Z	101650	#8 X 1-1/4" PHILIPS FLAT HEAD SELF-TAPPING SCREW - BLACK ZINC	2

**CAUTION!**

Do not use the Covermate in high wind conditions. Injury from the spa cover being blown over and impacting the spa user can occur.