

Step #1

Insert the front rail bracket into the side of the ModStep 2 riser and attach from underneath using the supplied 1/4 x 3/4" flat head machine screws, 1/4 flat washers and 1/4 nylon locknuts (see Fig. 1).

Step #2

Remove the 1/4 x 3/4" flat head machine screws, 1/4 flat washers and 1/4 nylon locknuts from one side of the back of the ModStep 3. Next, attach the side rail brackets using the hardware removed and using the same holes (see Fig. 2). Next, using the supplied #10 x 5/8" self tapping screws, finish attaching the front rail bracket and both side rail brackets to the side of the ModStep 3 (see Fig. 3).

Step #3

Insert the rail into the front rail bracket and both side rail brackets and attach using the supplied 3/8 x 2-3/4" hex cap bolts, 3/8 flat washers and 3/8 nylon locknuts (see Fig. 3).

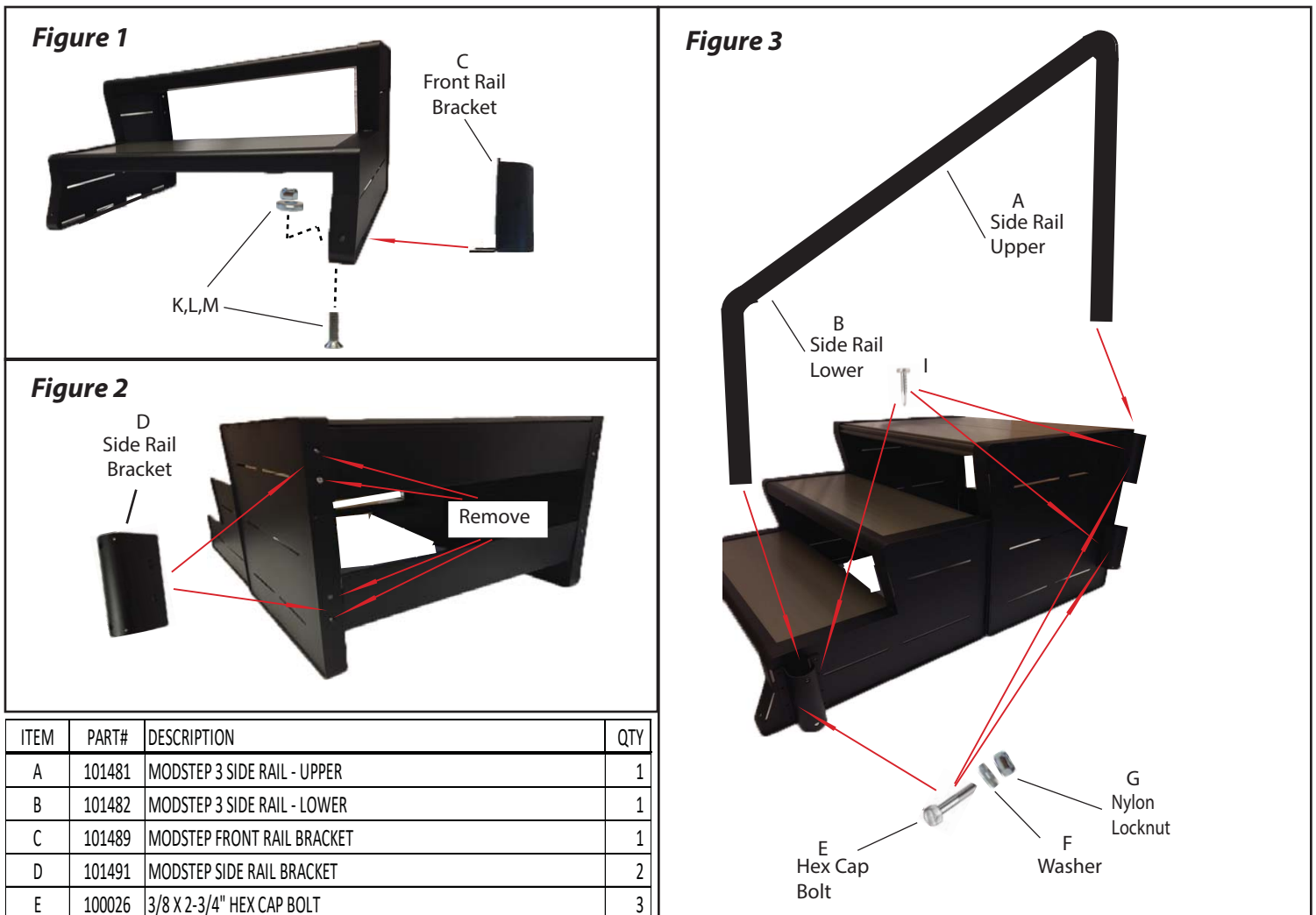

ITEM	PART#	DESCRIPTION	QTY
A	101481	MODSTEP 3 SIDE RAIL - UPPER	1
B	101482	MODSTEP 3 SIDE RAIL - LOWER	1
C	101489	MODSTEP FRONT RAIL BRACKET	1
D	101491	MODSTEP SIDE RAIL BRACKET	2
E	100026	3/8 X 2-3/4" HEX CAP BOLT	3
F	100012	3/8 FLAT WASHER	3
G	100011	3/8 THIN NYLON LOCKNUT	3
H	100015	LARGE BLACK DOME CAP	6
I	100013	#10 X 5/8" SELF TAPPING SCREW	19
J	100016	SMALL BLACK DOME CAPS	19
K	101396	1/4 X 3/4" FLAT HEAD MACHINE SCREW - STAINLESS	2
L	100608	1/4 FLAT WASHER	2
M	100607	1/4 NYLON LOCKNUT	2