

Figure 1



Foam Insert

Figure 2



C
Aluminum Plate Insert

Figure 3

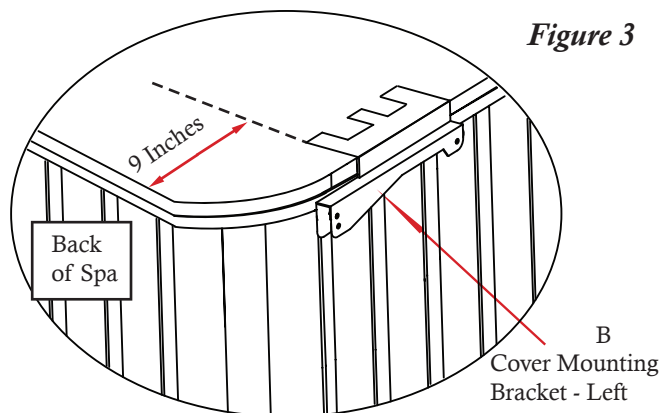

Figure 4

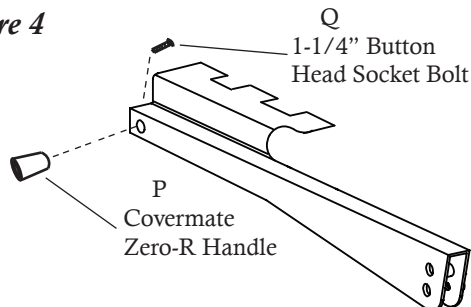

Figure 5

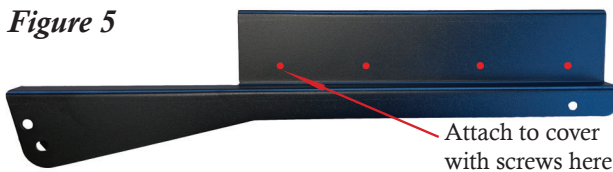
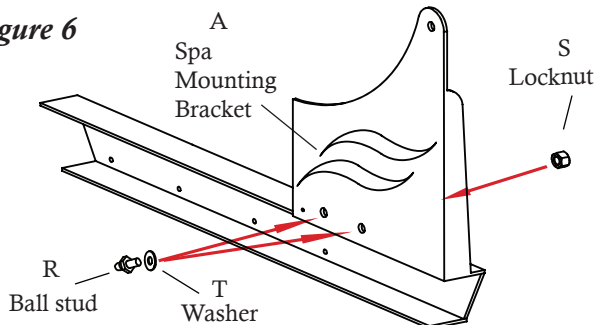

Figure 6



Step #1

Position the cover (in closed position) on the spa making sure that all four corners are properly positioned and square on the spa.

Step #2

Measure 9" from the back edge of the cover and make a mark on the cover. (Do this on both sides as this will determine the position for the cover brackets). **Note: If your spa has a 2 inch or less corner radius, measure 7 inches from the back edge of the cover, not 9 inches.**

Step #3

Flip the front half of the cover onto the back half of the cover. Unzip the back half of the cover exposing the white foam (see Fig. 1). Next, slide the aluminum plate insert inbetween the foam and the vinyl cover making sure the short edge of the aluminum plate insert is facing towards the acrylic of the spa (see Fig. 2). Slide the aluminum plate into the cover down to the marks made in step 2. Once in position, re-zip the cover.

Step #4

Re-position the cover (in closed position) on the spa making sure that all four corners are properly positioned and square on the spa.

Step #5

Attach the Covermate Zero-R handle to the cover mounting bracket using the supplied 1-1/4" button head socket bolt (see Fig. 4).

Step #6

Place the cover mounting bracket on top of the cover, making sure the back edge of the cover bracket is positioned at the marks made in step 2. **For determining L & R bracket, see Fig. 3.** Using (4) of the #10 x 1" self-drilling screws, attach the cover mounting brackets to the cover, making sure the screws hit the aluminum plates inserted in the cover in step 3 (see Fig. 5 for screw location). **When attaching the cover brackets, make sure to apply downward pressure on the top of the bracket to avoid any tenting of the bracket on the cover.**

Step #7

Attach the ball stud and washer to the cabinet mounting bracket in the back hole of the bracket (see Fig. 6). **Note: Once final installation has been completed, if the cover doesn't lift off the spa easily, move the ball studs forward one hole and re-attach the shocks.**

Step #8

Insert the 3/8 x 1-3/4" button head socket bolt into the top hole in the back of the cover mounting bracket. Make sure to install the rubber stop on the button head socket bolt once you insert the bolt through the outside flange of the cover mounting bracket. Secure the 3/8 washer and locknut to the opposite end of the button head socket bolt (see Fig. 7). **Note: Do not over-tighten locknut.** Next, attach the ball stud and washer to the cover mounting bracket (see Fig. 7).

Step #9

Attach the cabinet mounting bracket to the cover mounting bracket, in the bottom hole, using the supplied 3/8 x 1-3/4" button head socket bolt, washer and locknut (see Fig. 8).

Step #10

While pressing downward on the cover, swing the cabinet bracket up until it is level and parallel with the spa acrylic. Attach the cabinet bracket using the supplied #10 x 2" mounting screws (see Fig. 8). **Note: We have added an additional mounting screw hole to the bracket for increased support and stabilization (see Fig. 8).**

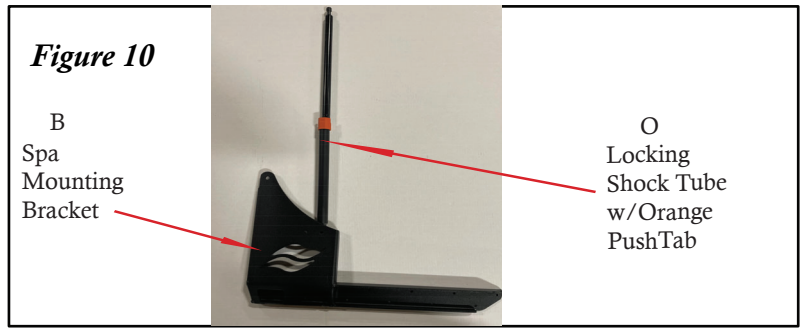
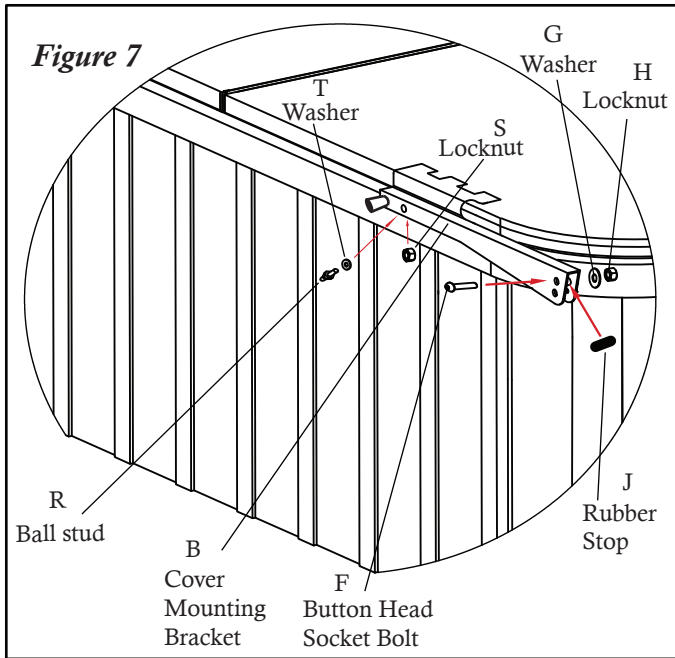

Step #11

Slide the filler bracket in behind the cabinet mounting bracket and attach to the spa cabinet using (3) #10 x 2" mounting screws (see Fig. 9). Attach the cabinet mounting bracket to the filler bracket using (4) #10 x 1" self-drilling screws (see Fig. 9).

Step #12

Gently raise the cover into the upright position, making sure to keep a firm grip on the cover. Attach the shocks to the cover mounting bracket ball stud and the cabinet mounting bracket ball stud. *Note: The portion of the shock with the red push tab is what gets attached to the cabinet mounting bracket (see Fig. 10).* Next, attach the "Push to Release" sticker to the shock directly under the red push tab.

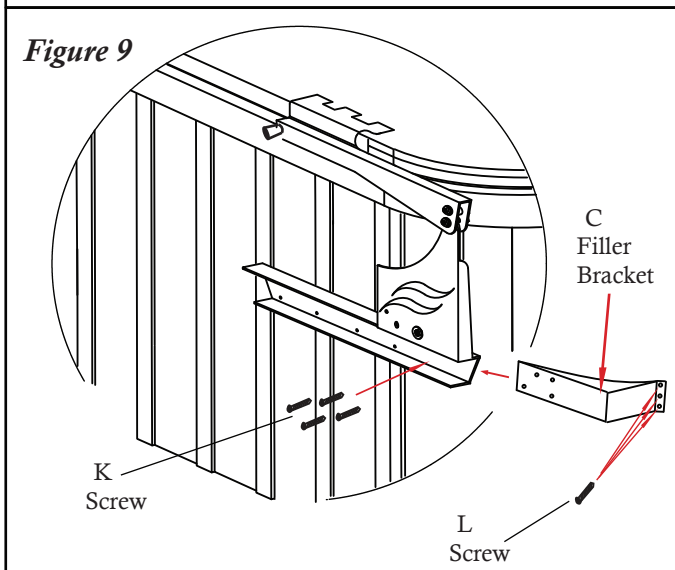
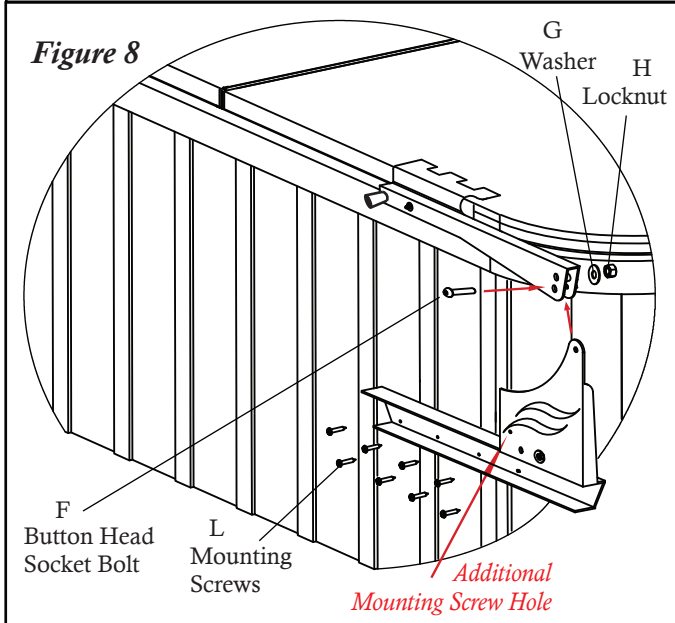

Operation of the Covermate Zero-R

1. Fold the first half of the spa cover off the spa. Gripping the foam grip, motion the spa cover into its vertical upright position.

2. **Important:** When closing the spa cover, always make sure to unlock the shock by pushing on the unlock tube that says "Push to Release" before pulling the Covermate down to prevent possible lift damage.

CAUTION! Do not use the Covermate in high wind conditions. Injury from the spa cover being blown over and impacting the spa user can occur.

ITEM	PART#	DESCRIPTION	QTY
A(L)	101990	CM ZERO-R SPA MOUNTING BRACKET (L)	1
A(R)	101991	CM ZERO-R SPA MOUNTING BRACKET (R)	1
B(L)	101994	CM ZERO-R COVER MOUNTING BRACKET (L)	1
B(R)	101995	CM ZERO-R COVER MOUNTING BRACKET (R)	1
C(L)	100577	CM ZERO-R FILLER BRACKET - 460 (L)	1
C(R)	100578	CM ZERO-R FILLER BRACKET - 460 (R)	1
D	102146	CM ZERO-R ALUMINUM PLATE INSERT	2
F	101749	3/8 X 1-3/4" BUTTON HEAD SOCKET BOLT - BLACK ZINC	4
G	100951	3/8 WASHER - BLACK ZINC	4
H	100838	3/8 LOCKNUT - BLACK ZINC	4
J	101885	RUBBER STOP - 1-1/8"	2
K	101996	#10 x 1" PHILIPS PAN HEAD SELF-DRILLING SCREW	16
L	100359	#10 X 2" PHILIPS PAN HEAD MOUNTING SCREW	26
M	100016	SMALL BLACK DOME CAPS	42
N	101997	SHOCK	1
O	102128	SHOCK - LOCKING	1
P	101552	COVERMATE ZERO-R HANDLE	2
Q	101751	5/16 X 1-1/4" BUTTON HEAD SOCKET BOLT	2
R	100244	5/16 BALL STUD	4
S	100032	5/16 NYLON LOCKNUT	4
T	102321	5/16 STRUCTURAL FLAT WASHER - BLACK ZINC	4
U	100034	BLACK HEX DOME CAP	2